

How effective is sensitivity analysis with probabilistic models?

Luca Santinelli, ONERA



Probabilistic Real-Time System

« A probabilistic real-time system is a system where at least one parameter is described with a probability distribution »

Probabilities for modeling, probabilistic schedulability analysis (deadline miss ratio, etc.) for analysis

Probabilistic models

Probabilistic Worst-Case Execution Time (pWCET):
[continuous/discrete] distribution that upper bound any execution time profile

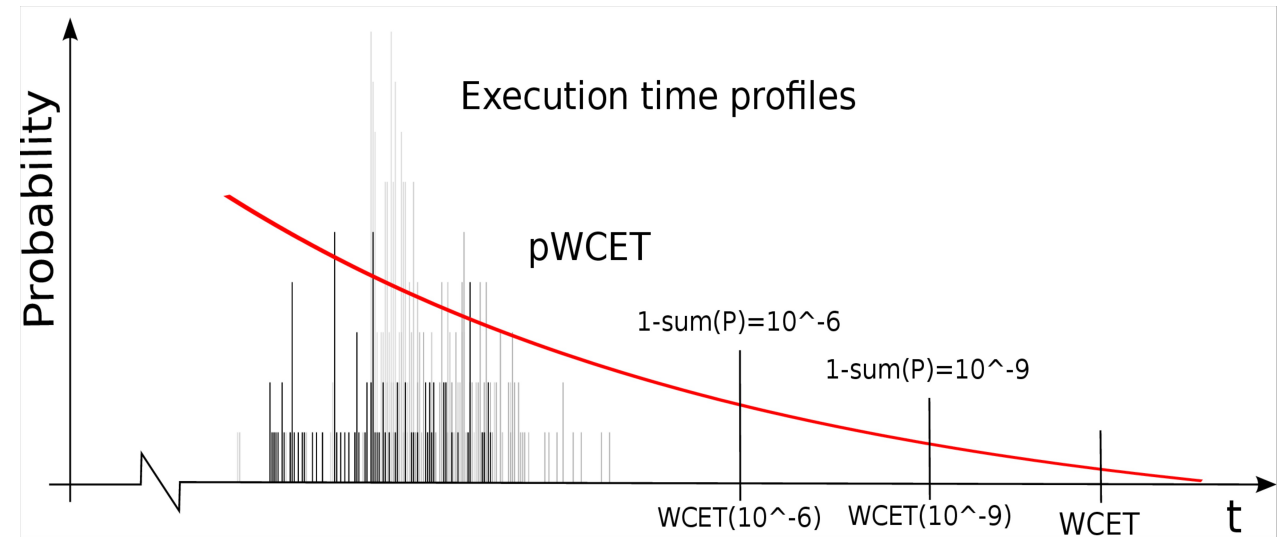
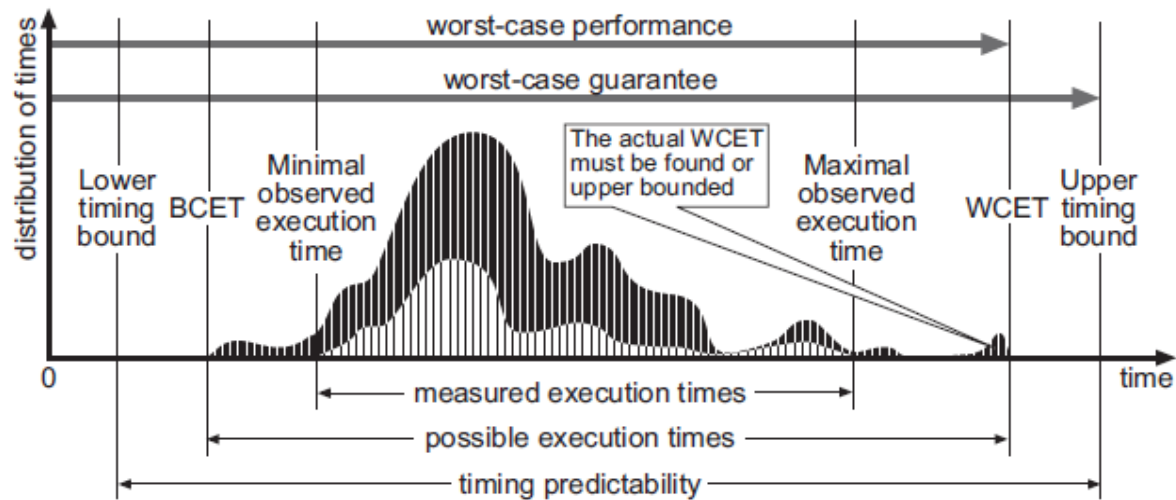

Resource request/demand

- Resource demand: the demand bound function dbf of task: the resource requested by the task to execute by its deadline. Task set dbf: sum of all tasks dbf – Earliest Deadline Scheduling (EDF) scheduling
- Resource request: resource bound function (rbf) of a task, upper bounds the task resource request.
- The level-i workload wbf_i is the resource request from a task, and it includes all the contributions of all higher priority tasks -- Fixed-Priority (FP) scheduling

$$rbf_i(t) \stackrel{def}{=} \max \left\{ 0, \left(\left\lceil \frac{t}{T_i} \right\rceil \cdot C_i \right) \right\}$$

$$wbf_i(t) \stackrel{def}{=} \sum_1^{hp(i)} rbf_k$$

$$dbf_i(t) = rbf_i(t - D_i)$$

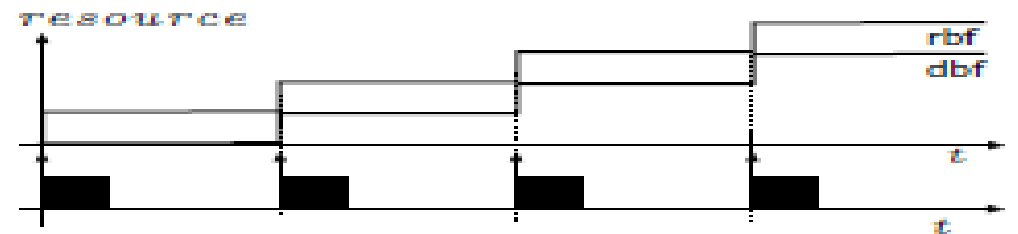

(a) Task τ_i execution with rbf and dbf

Resource provisioning

The computational resource is provided by reservation mechanisms (servers)

The supply bound function sbf is the minimum amount of time (computational resource) provided by a server – lower bound

It exists the linear approximation to sbf :

$$lsbf \quad lsbf(t) \stackrel{def}{=} \max\{0, \alpha(\Delta)\}$$

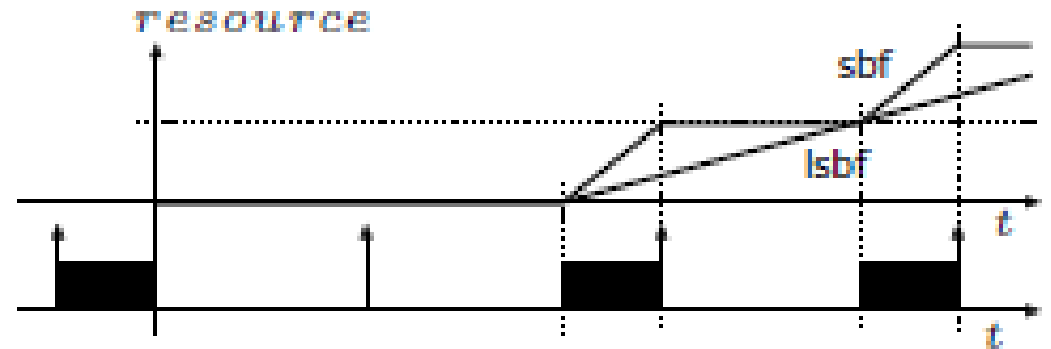

(b) Periodic server sbf with its linear approximation $lsbf$

Schedulability with probabilities

- **Diaz from 2002:** shrink and convolution, backlog; deadline miss ratio
- **EDF, FP with probabilities modeling pWCET and Period (pPeriod, pMIT):**
 - convolution and backlog; deadline miss ratio
- **probabilistic Calculus (EDF and FP):**
 - probabilistic dbf, probabilistic rbd, probabilistic wbf
- **Probabilistic guarantees:** shared resources (pDeadline)
- **Formal approaches:** Automata (probabilistic timing automata)?, Stochastic Petri Nets, “full” Markov Chain?
 - Deadline miss ratio, probabilistic response time

Main hp: statistical independence between pWCETs

Schedulability with probabilities

From probabilities, **multiple behaviors**: multiple dbf (p-dbf), multiple wbf (p-wbf) each with a probability associated

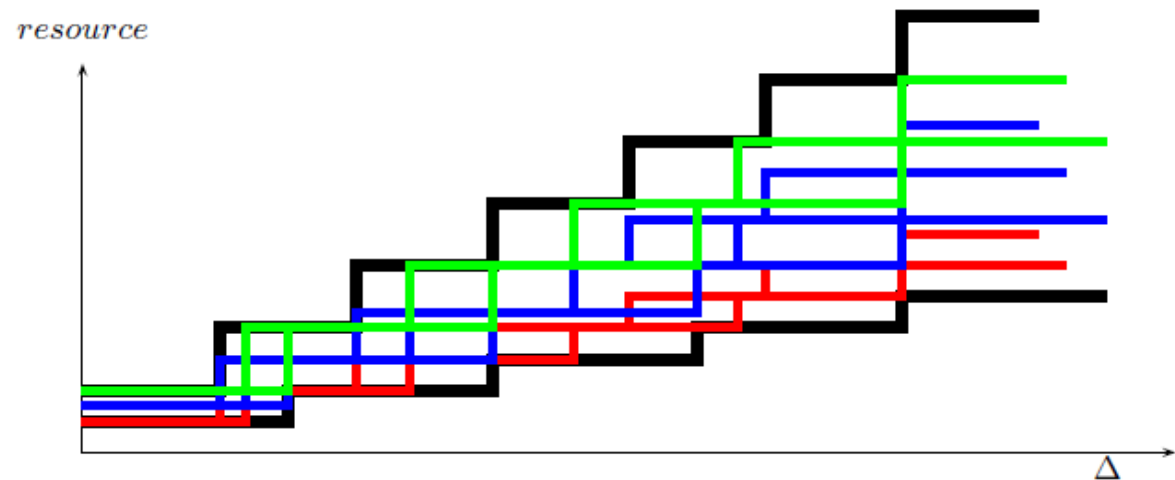
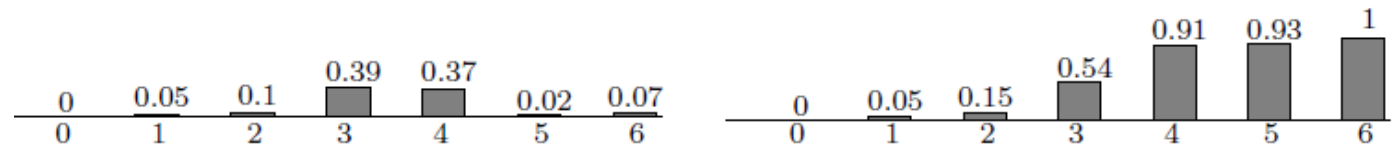

Fig. 6. Probabilistic curve: ordered multiple curves $\phi_i(\Delta, x)$.



Schedulability with probabilities

Schedulability from comparing resource request/demand with resource provisioning

$$\forall t \in D \text{ dbf}_T(t) \leq \text{sbf}_S(t)$$

Compute probabilistic Worst-Case Response Time (pWCRT) for jobs and tasks
Compute deadline miss probability for jobs and tasks
... other info?

Cost to extract them is very high!

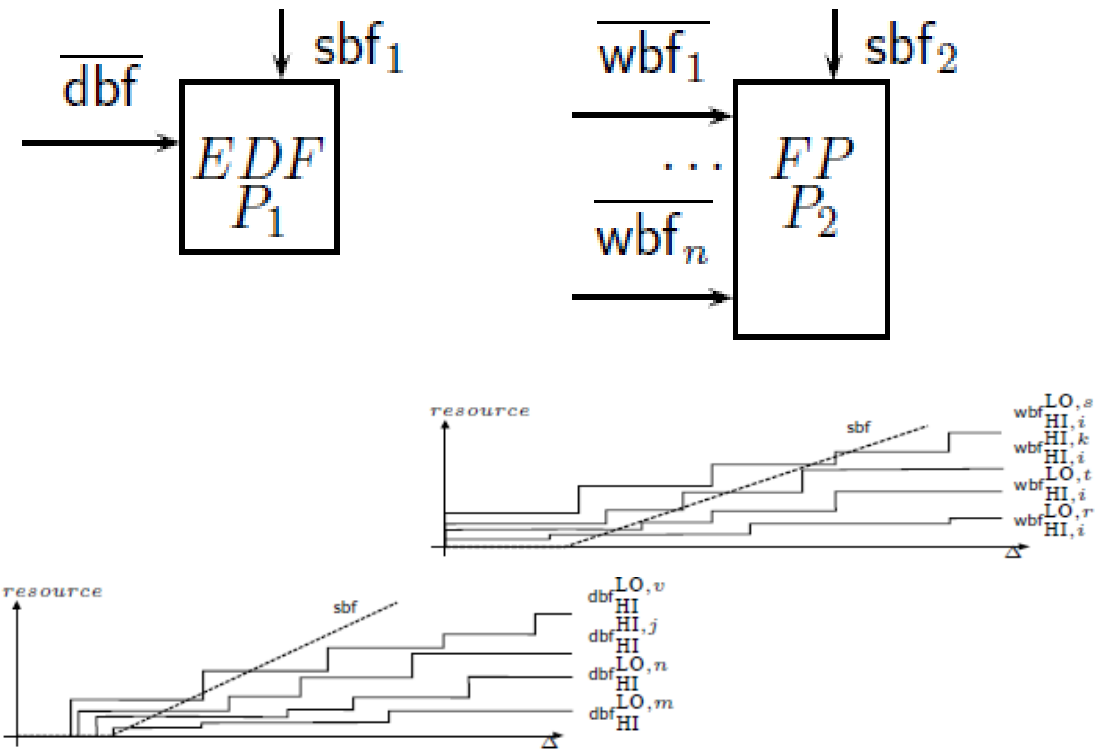

Open problem

Probabilistic models embeds multiple behaviors, more flexibility, but analysis too complex (include them all!!!)

Make use of abstract interpretation and sensitivity analysis with probability

- **Efficient use of probabilities (better make use of complexity), leverage probabilities (into scheduling decisions), extract more info!**
- **Exploring (α , Δ)-space and C-space with their probabilistic versions**

(α, Δ)-space

Schedulability (EDF, FP):

$$\forall t \in D : \text{dbf}(t) \leq \alpha \cdot (t - \Delta)$$

$$\forall i \exists t \in \text{Sched}P_i : \text{wbf}_i(t) \leq \alpha(t - \Delta)$$

Abstract representation, space of resource provisioning, feasibility regions

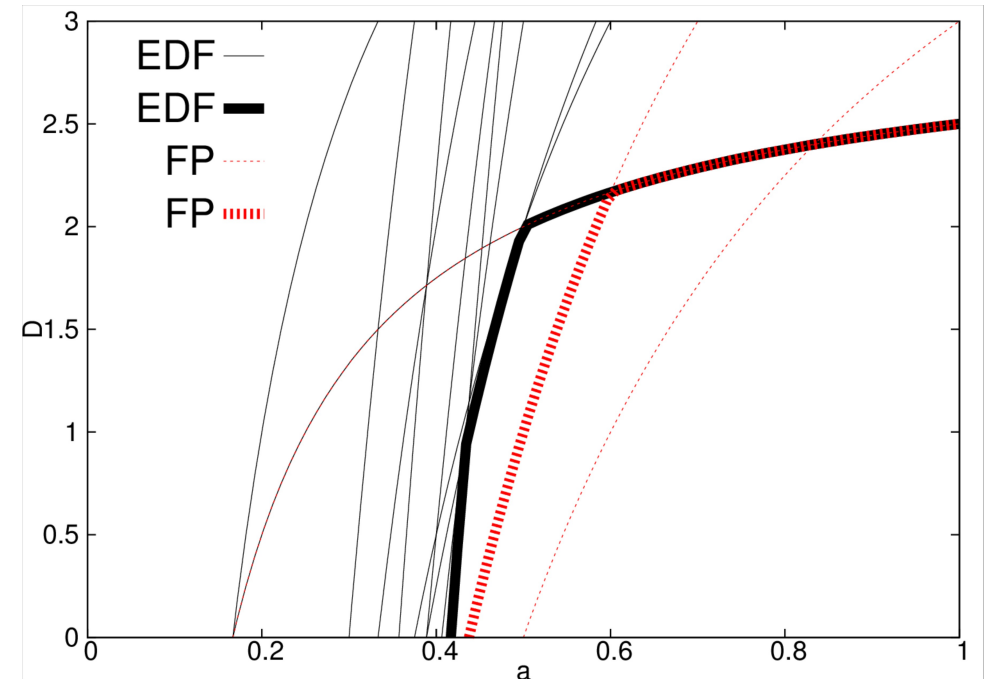

Probability of happening meaning probability of schedulability

(α , Δ)-space

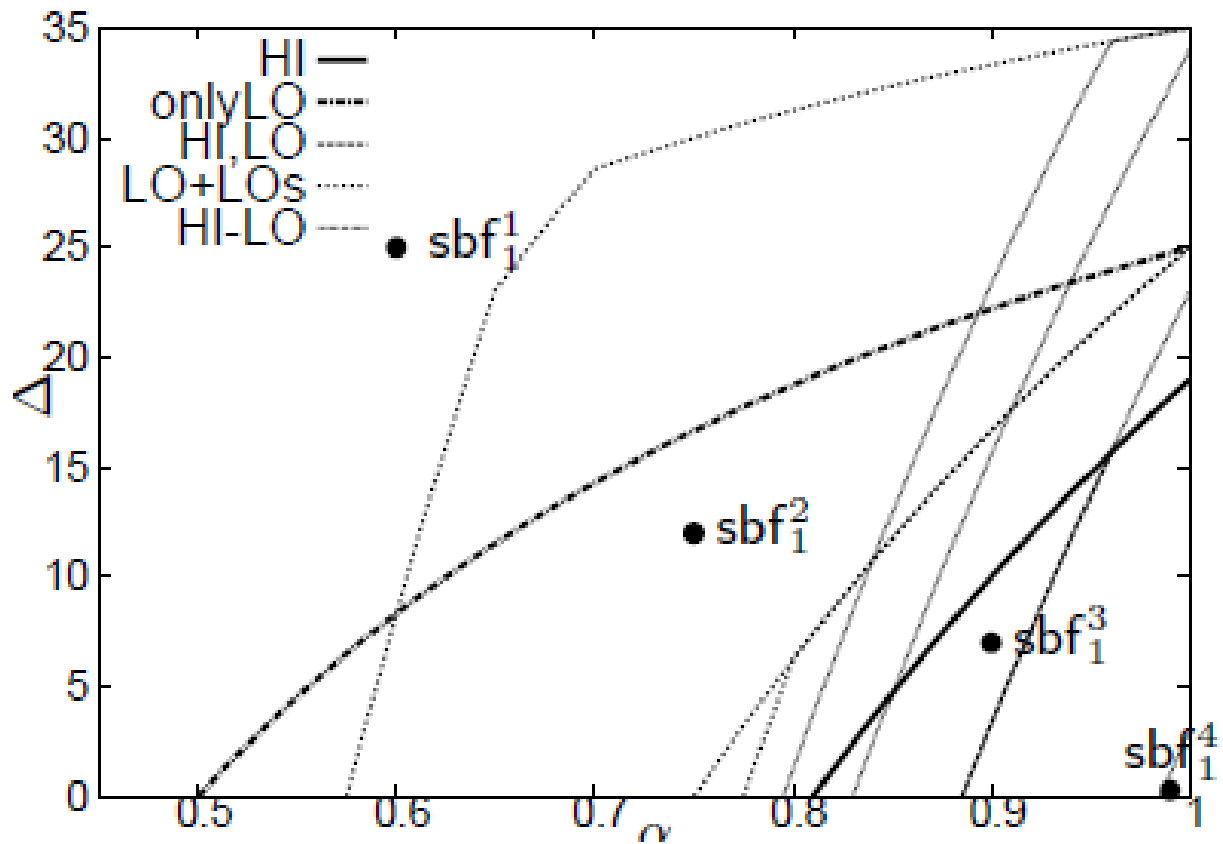

Probability of happening meaning probability of schedulability

pC-space

Space of WCETs

Probability of happening, compared with feasibility means
schedulability probability

Difference between deterministic and
probabilistic C-space: possible WCETs

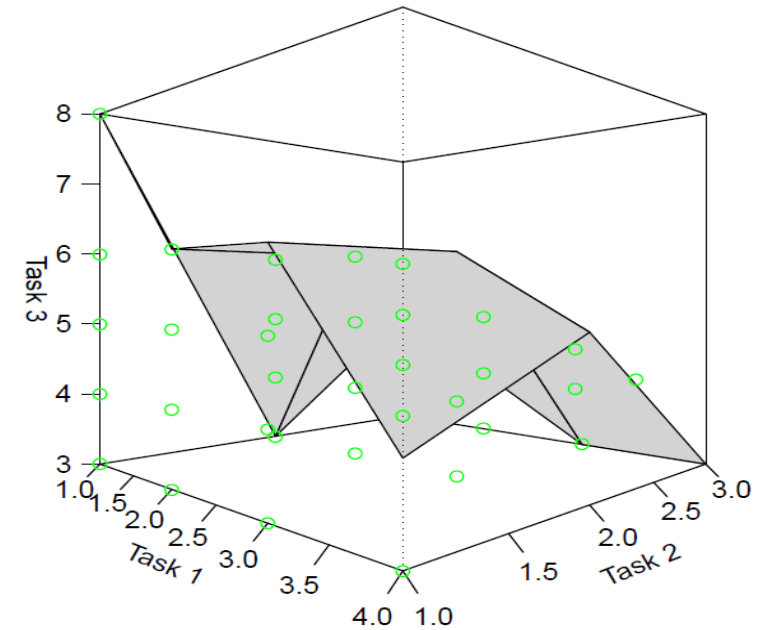

Sensitivity analysis: \Beta-parameter

Sensitivity analysis could be a way to “efficiently” make use of flexibility from probabilities!

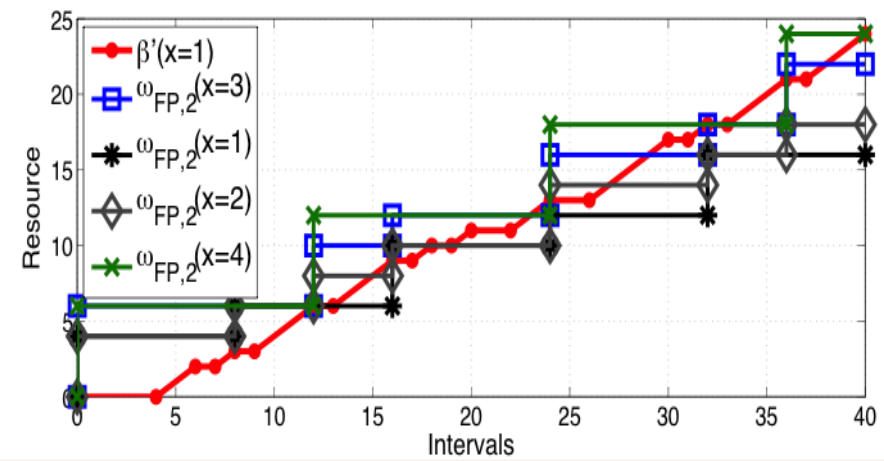
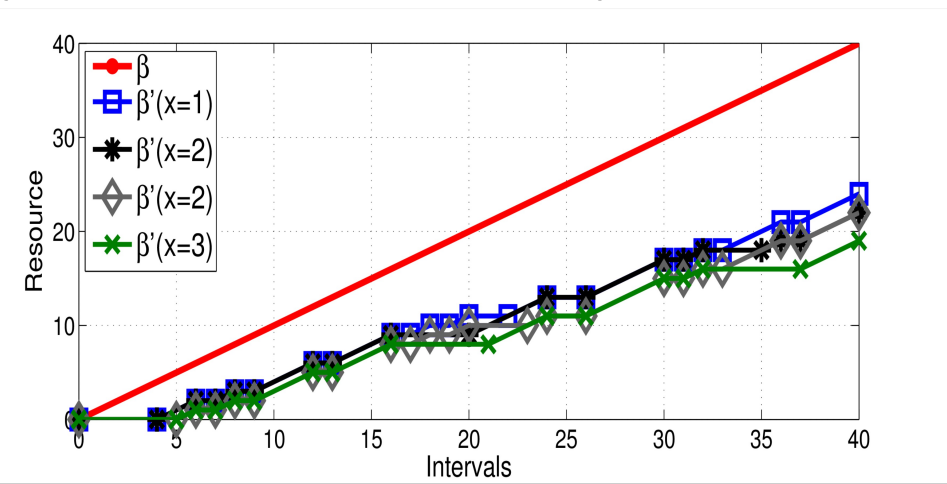
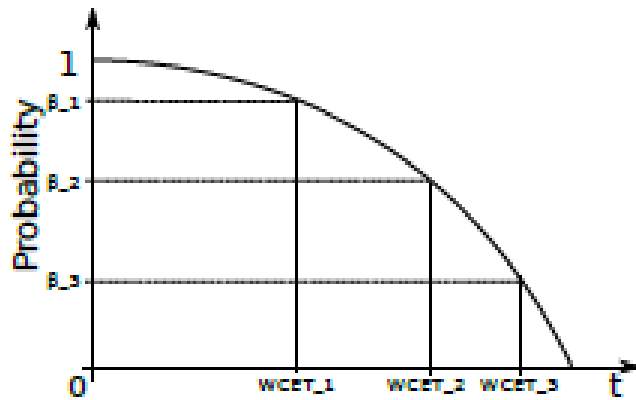

Sensitivity analysis

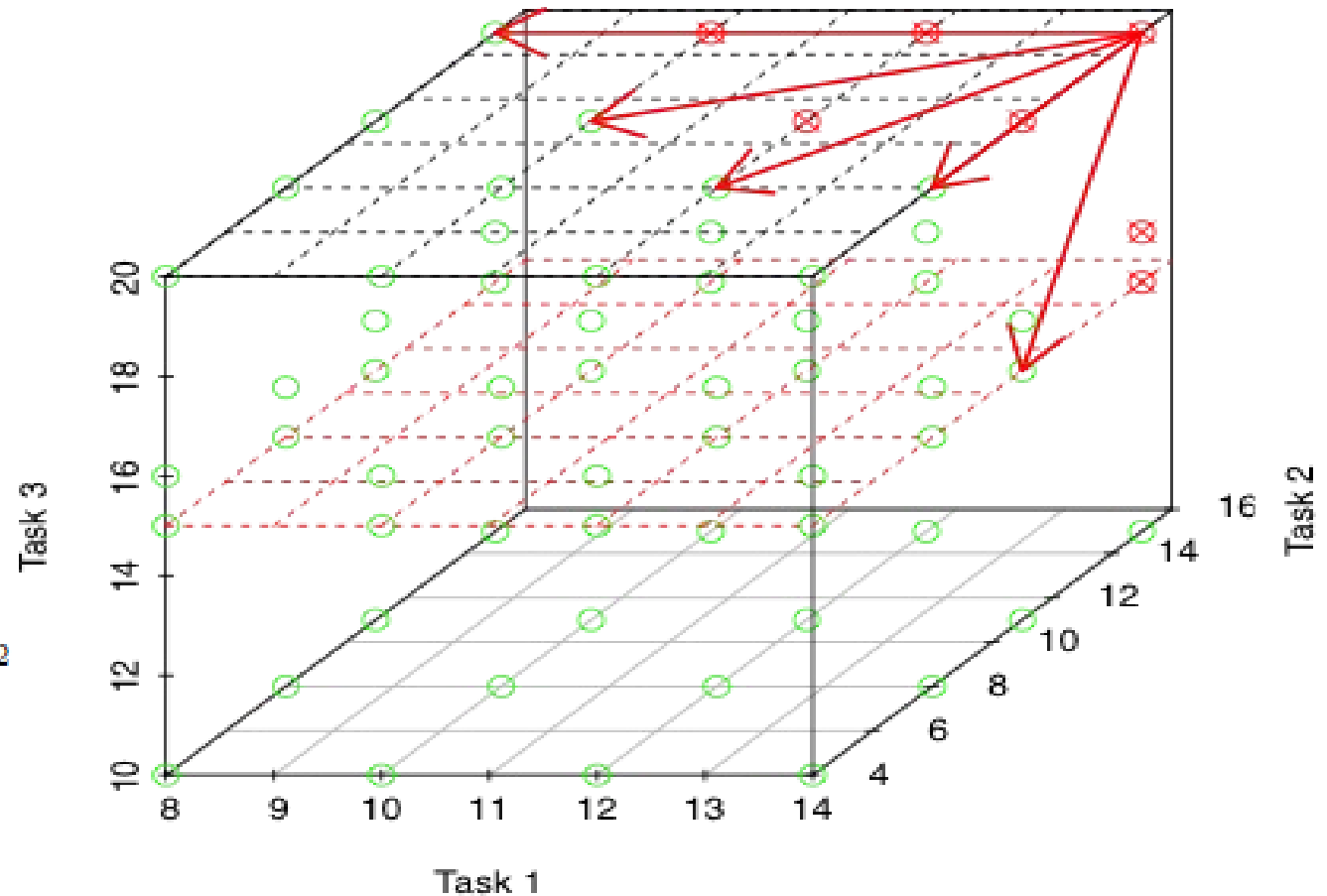
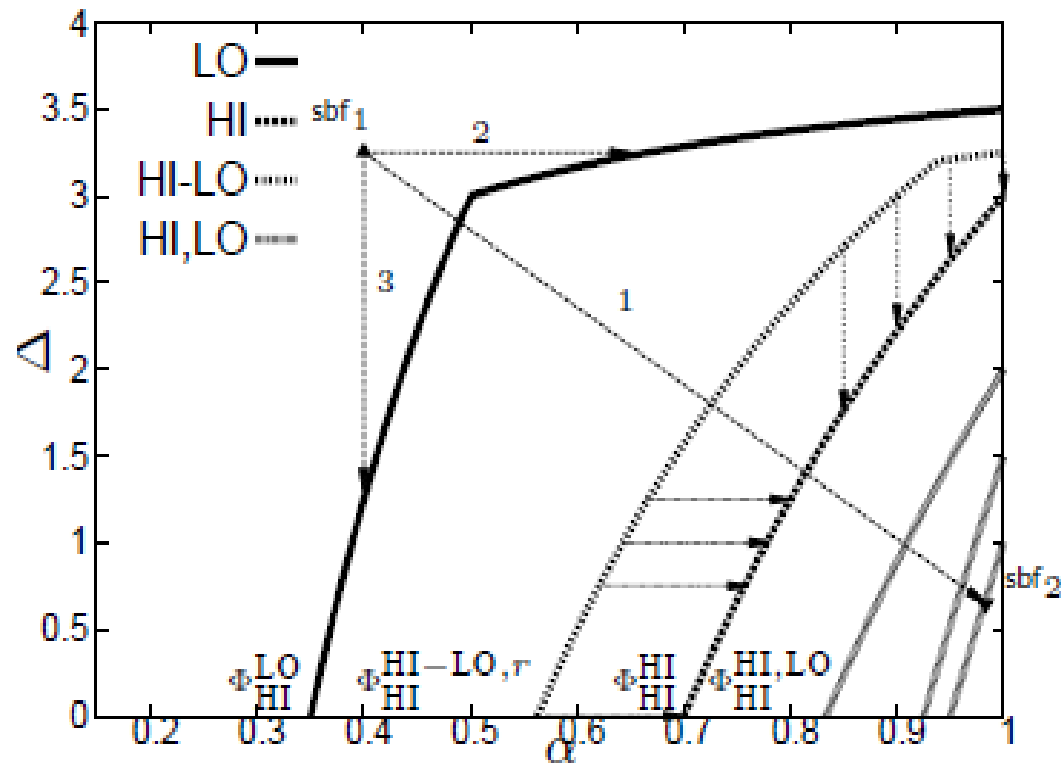

Thank you
luca.santinelli@onera.fr

